

Solar Space Wings™



Muscle Wires® Moving Electronics Kit

This Solar Space Wings™ kit demonstrates the amazing capabilities of Muscle Wires® that actually shorten in length when powered!

- *Silent, graceful motion.*
- *Stands 15 cm (6 in.) tall.*
- *Flaps up to 15 times/min.*
- *Includes circuit board, all parts, Flexinol®, history and information on Shape Memory Alloys, and complete instructions. (Requires soldering).*
- *Uses any light source to power.*
- *An excellent introduction to electronics.*

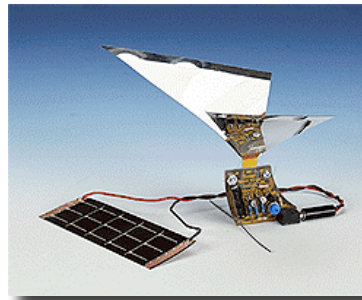

Easily assembles in under an hour. You will need: a soldering iron for electronics, solder, moist sponge, wire stripper, side cutter, transparent tape, nearby type G star or other bright light source. Electronics experience helpful but not required.

Where to put your Solar Space Wings? On a desk lamp. In a potted plant. On a computer monitor. Where the sun shines.

DYNALLOY INC
14762 Bentley Circle
Tustin, CA 92780
USA

Phone 714-436-1206
Fax 714-436-0511
Email flexinol@dynalloy.com

Visit MuscleWires.com for more information

1.0 Introduction

Create motion from sunlight! This Solar Space Wings™ Kit demonstrates the amazing capabilities of Muscle Wires® that actually SHORTEN IN LENGTH when electrically activated.

The solid-state actuator circuit is powered by a thin film solar cell. It stores up the energy of the sunlight until it has sufficient power to activate the Muscle Wire®, then releases it in a burst. No batteries or external power supply required!

Demonstrate these new technologies right on your desk top! Kit requires soldering, basic tools plus sunlight or any bright light source.

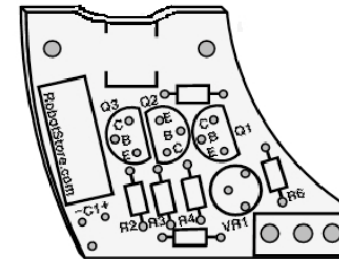

Fig. 1.1

2.0 Parts List

Item	Qty	Location	Description
1.	1	R1	Resistor, 20Ω ¼ W 5% (red black black gold)
2.	1	R2	Resistor, 105KΩ, ¼ W 1% (brown black green orange brown, blue body)
3.	2	R3, 4	Resistor, 56.2Ω W ¼ 1% (green blue red red brown, blue body)
4.	1	R5	Resistor, 2.4Ω ¼ W 5% (red yellow red gold)
5.	1	R6	Resistor, 1.0Ω ¼ W 5% (brown black gold gold)
6.	1	VR1	Potentiometer, 2K Ω ¼ W 5%
7.	2	C1	Capacitor, 0.33 F, gold, radial (yes, that's 1/3 Farad!)
8.	2	Q1, 3	Transistor, PN4401 NPN general purpose
9.	1	Q2	Transistor, PN3906 PNP general purpose
10.	1	J1	Solar Cell, 114 x 37mm, 3 Volt
11.	1	J1	Plug, 2.5mm Mini, mono
12.	1	J1	Jack, 2.5mm Mini, mono, PCB mount
13.	1	J2-3	Muscle Wire, Flexinol®, 100 HT (90°C), 6cm long
14.	1	-	PCB, Solar Space Wings, Rev-
15.	2	J2, 3	Screw, 4-40 x ¼"
16.	2	J2, 3	Nut, Hex 4-40
17.	1	J1	Wire, Hook Up, Red, 8"
18.	1	J1	Wire, Hook UP, Black, 8"
19.	1	AA1	Wingbase Strip
20.	1	-	Mylar, 5mil, Mirrored, 3" x 4.5"
21.	1	Stand	Instruction, Solar Space Wings (these pages)

3.0 Build It

If you have not soldered or assembled electronics before, please see our PDF “How to Solder” on our website at MuscleWire.com, or get the assistance of an experienced bard assembler. In general, assemble the Printed Circuit Board starting with components that have the lowest height above the board, and work upwards in height. Always check for the correct part (watch the resistor color codes), the location of the part (don’t put it in the wrong place), and its orientation. Many parts, like capacitors and transistors, can be damaged or destroyed if installed and powered the “wrong” way.

Suggested order of assembly:

- 3.1 Six resistors, R1 to R6 (note their values and locations. Their orientation matters only for appearance). Bend the leads, insert through holes then bend them slightly outwards to hold the part flush against the board. Solder in place. Trim away excess leads.
 - 3.1.1 R1 – Resistor, 20Ω (red black black gold)
 - 3.1.2 R2 – Resistor, 105KΩ (brown black green orange brown, blue body)
 - 3.1.3 R3 – Resistor, 56.2Ω (green blue red red brown, blue body)
 - 3.1.4 R4 – Resistor, 2.4Ω (red yellow red gold)
 - 3.1.5 R5 – Resistor, 1.0Ω (brown black gold gold)
- 3.2 One variable resistor (also called a potentiometer or pot for short) into location VR1.
- 3.3 Two capacitors at location C1 (direction critical—note orientation of “+” and “-” leads on board). You need to first solder the two together by twisting the leads from on around the other and soldering them together. Make sure “+” on both capacitors attach to “+” on the board and “-” to “-”. Trim away excess leads.
- 3.4 Two PN4401 NPN transistors at location Q1 and Q3 (direction critical—note orientation of flat side). Push them in until they stand about one centimeter above the board. Solder and trim.
- 3.5 One PNP transistor at location Q2 (direction critical—note orientation of flat side). Push in until it stands about one centimeter above the board, then solder and trim away excess leads.

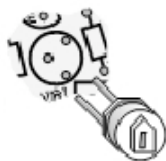

Fig. 3.2

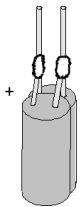

Fig. 3.3

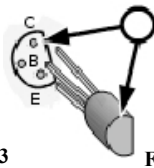

Fig. 3.4

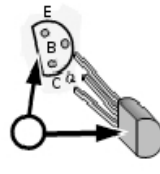

Fig. 3.5

- 3.6 One Jack (little black box) at J1 (direction critical—hole for plug extends away from board).
- 3.7 Insert a screw into J2 from the FRONT of the circuit board and into J3 from the BACK (see figure 3.9). Secure in place with nuts, but do not tighten until later.
- 3.8 Straighten the paper clip, insert it at the hole marked “Stand” and solder in place with an equal length extending from each side of the board. Bend it slightly so it supports the PC board.
- 3.9 Position one end of the Muscle Wire under the screw head at J2 and the other under the screw head at J3. Note how it arches over the top of the board at AA1. Temporarily secure both the screw, leaving as much slack in the Muscle Wire as possible.

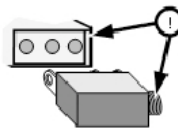

Fig. 3.6



Fig. 3.8



Fig. 3.9

This completes the circuit assembly of your Solar Space Wings circuit. Double check all connections and solder points. Make sure all parts are in the correct locations and orientations, that the solder joints are bright, clean and cone shaped (not dry or blobby), that leads are trimmed, that there are no stray solder bridges or other connections to interfere with the circuit’s operation. Next, assemble the Solar Cell, wire leads and mini plug.

- 3.10 Place the solar cell on a smooth, flat surface and carefully heat one of the corner connecting pad and apply a small amount of solder. This “tins” the pad and makes it easier to solder the wires in place. Repeat for the other corner pad.
- 3.11 Strip the ends of the black and red wires and pre-tin them with a small amount of solder.
- 3.12 Apply solder to the tip of the soldering iron, then press it against one of the copper strips on the edge of the solar cell, melting through the plastic coating until the solder flows onto the copper. Solder the RED lead to the “+” strip and the BLACK lead to the “-” strip per figure 3.12. Use care to not overheat the cell. Double check that the wires are attached correctly or damage can occur to your circuit. Gently bend the leads and twist them together as shown to help prevent the wires from pulling off of the cell.
NOTE: The advanced thin film solar cell in this kit is quite rugged, but care should be used not to overheat it (i.e. Don’t place it close to a hot light bulb) as it may melt, deform or damage the cell.
- 3.14 Remove the mini plug’s cap and thread the red and black wires from the solar cell through the small end of the cap first. Note: Be sure to solder the RED wire (+) to tip and BLACK wire (-) to the body. If they are reversed, damage can occur to your circuit. Crimp the strain relief and replace the cap.



Fig. 3.12

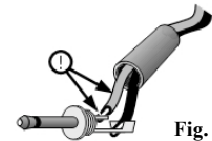

Fig. 3.14

Initial Circuit Test

Turn the potentiometer counterclockwise fully. You will feel it stop—don’t over tighten. If you have access to a voltmeter, connect it across the leads of the capacitor. Plug the solar cell into the circuit board and place it in bright sunlight (or alternately under a desk lamp—but no closer than 30cm (12 inches) from a 100 Watt bulb or the heat may damage the cell). If you have the voltmeter connected you should see the voltage rise until the circuit fires. This takes 20-30 seconds in direct sunlight, up to several minutes in bright indoor light. At around 2.75 volts, the circuit will fire and you will see the voltage drop to around 1.6 volts. The circuit has partially discharged the capacitor through the Muscle Wire. You should be able to see the Muscle Wire move slightly.

- Double check all solder joints for:
 - Wires in wrong locations
 - Bridged or short-circuited solder joints
 - Weak solder joints
- Check the output of the solar cell with a voltmeter and make sure it produces about 3 volts in bright light.

Note: On a solar cell, the voltage remains constant, no matter the light level, but the current produced by the cell varies with the light level. This is called the “photoelectric effect”. In 1905, Albert Einstein got a lot of attention when he became the first to explain this phenomena and he later received a Nobel Prize in Physics for it.

As an alternate, you can power the circuit with two AA cells in series or any other 3 volt source. Test the source with a voltmeter to be sure the TIP is POSITIVE. If it still does not function, refer to the schematic and use a voltmeter to check for proper input voltage, circuit continuity and output signal at pin “B” on transistor Q1.

When everything works correctly, go on to Section 4.

4.0 Assemble the Wings

After verifying that the circuit built in Section 3 functions, remove power.

- 4.1 Loosen one end of the Muscle Wire and move it out of the way. Fold the wing base strip into a “Y” with the CENTER adhesive strips facing UPWARDS (as shown at the right).
- 4.2 Remove the backing from one of the END adhesive strips. Press the adhesive tab to the board at location AA1 with the strip extending straight away from the edge. Repeat on the other end, positioning the strip so that when closed, the wing base points straight away from the board. Look at figure 4.9. try to position the wing base very low on the boards. When the center of the “V” in the center of the wing is all the way down, it should almost touch the PC board. About one eighth of an inch gap is perfect.



Fig. 4.1



Fig. 4.2



Fig. 4.2

- 4.3 Pass the Muscle Wire through the “Y” of the wing base and position the wire so it just begins to pull the wing base closed. Tighten the screw to hold the wire in place.
- 4.4 With a hobby knife and straight edge ruler, cut the polyester sheet from corner to corner and trim the lower corners to make a small flat edge 1cm (1/2 inch) long.
- 4.5 Remove one backing strip from the center of the wing base. Position a wing with the small flat edge in the wing base’s “V” and the longest edge positioned above the stand wire. Leaving a small gap between the bottom of the wing and the Muscle Wire, press the wing onto the adhesive.
- 4.6 Attach the second wing, aligning it with the first. Press both wings securely to the adhesive.
- 4.7 Plug the solar cell into the circuit board. Turn VR1 to change the rate of motion.
- 4.8 The weight of the wings will extend the Muscle Wire. Let the circuit run for a few cycles, then adjust the Muscle Wire so the wings nearly close when up, and relax to about 100°. There is a point where it works perfectly—keep trying until you find it. If the wings lean to one side or the other when up, lift on end of the wing base from the board and raise or lower it until the wings close directly over the board.
- 4.9 After operating for a few hours, the wing base mechanism may settle and require slight adjustment. Finally, when completely adjusted, secure the wing base with a piece of transparent tape on each side of the board.



Fig. 4.4

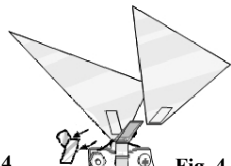

Fig. 4.5

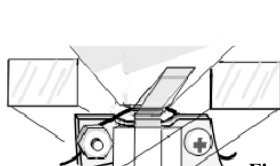

Fig. 4.9

Depending on the flapping rate set by VR1 and the light level on the solar cell, the wings should move every 10 to 60 seconds. Place your completed Solar Space Wings in a well-lit location, safe from curious cats and hungry vacuum cleaners Plug it in and watch it go!

5.0 How it Works: Schematic and Theory of Operation

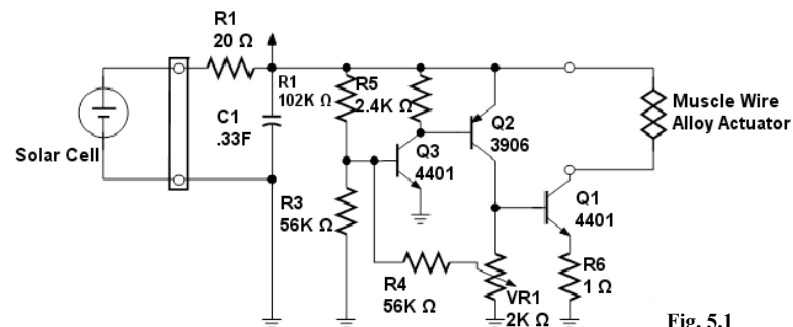

Fig. 5.1

This schematic shows the basics of the solid-state actuator technology. At initial power up, all transistors are off. Light striking the solar cell creates a current, which, in turn, creates a voltage across the capacitor, C1, and at the base of Q3, but in smaller proportion according to the values of R2, R3, R4 and VR1.

When the base (B) of Q3 receives about 1 microamp (μA) of current, Q3 begins to turn on, then so does Q2. As Q2 collector begins to conduct, the voltage on VR1 begins to increase. R4 feeds part of this voltage change back as increased drive current to the base of Q3 (a positive feedback loop) so that Q2 reaches its maximum conduction very quickly. As Q2 supplies about 200 μA , Q1 begins to turn on.

The voltage at the base of Q1 rises to a value of about 1 volt when on. R6 at 1 ohm provides some negative feedback to limit the gain of Q3 and decrease the maximum load current. When Q1 is on, C1 discharges through the Muscle Wire at AA1 causing it to heat and contract and lift the wings. C1 empties until the operating voltage is too low to sustain the on condition of Q3. When the voltage drops so low that Q3 cannot conduct over about 200 μA in its collector, Q3 begins to turn off hard and thus Q2 and Q1, until they are all fully off. Resistor R5 assures that normal tiny leakage currents do not get magnified by the various gain stages into significant drains on the charging circuit. Resistor R1 is required for battery or AC adaptor operation (using two AA cells in series or a 3 Volt 50mA AC adaptor, either with a 2.5 mm plug wired tip positive). It may be replaced by a short length of wire for solar-only use. However, it produces minimal loss and can be left in place for all operations. The charging cycle begins again, but now from a middle level voltage, typically 1.4 volts, instead of from 0 volts, and the circuit oscillates stably with a time constant depending on both the load resistance and the charging rate via resistor R1.

The circuit is intended to use a 3.5 volt (measured with no load) solar cell providing 1 to 15 milliamps (mA) of charging current. Circuit drain is about 15 μA while charging, but requires about 200 μA to trigger.

If VR1 is set part way over its range, the hysteresis will be proportionally smaller. If it is set too low, there will not be sufficient positive feedback to cause the Q3 and Q2 circuit to turn on fully.

The solar cell provided can supply about 15 mA in direct sunlight. The circuit is not recommended, as wired, for operation from very low current sources (e.g. in low light levels producing under 0.5 mA). The value of R5 can be increased for a marginal increase in low lighting condition operation range—but given normal loading, even 1 mA net charging gives only one operation about every 3-5 minutes.

For more on solar cells, visit NASA’s web page at:

<<http://science.nasa.gov/headlines/y2002/solarcells.htm>>

6.0 About Muscle Wires®

Muscle Wires® belong to the class of metals known as Shape Memory Alloys (SMA's) having crystal structures that can assume different shapes at distinct temperatures. At low temperatures (part C at right), Muscle Wires® can be easily stretch (to A), then when heated, they return to their original shape with a usable force and speed (part B).

In 1932, Swedish researcher Arn Ölander observed that shape recovery abilities of a gold-cadmium alloy and noted its potential for creating motion. In 1950, L.C. Chang and T.A. Read, at Columbia University in New York, used x-rays to study the alloy and to understand the phase changes of its crystal structure. In 1961, while searching for non-corrosive marine alloys, a team led by William Beuhler at the U.S. Naval Ordnance Laboratory (NOL) found that shape memory effect in an alloy of nickel and titanium. They named the alloy nitinol (pronounced "night in all"), an acronym of nickel, titanium and NOL. On disclosure of their observations their discovery generated much interest.

During the 1960's and 70's, researchers worldwide observed the shape memory effect in various titanium, copper, iron and gold alloys. NASA studied SMA's for applications such as satellite antennas that would expand from the heat of the sun, and other experimenters developed a variety of engines that operated on hot and cold water. Universities and companies researched SMA's, and some commercial applications resulted. Among the most successful applications, Raychem Corporation introduced a line of SMA pipe connectors that would shrink to fit and provide highly reliable seals for jet engines and hydraulic systems.

In 1986, China hosted the International Symposium on SMA's which saw the presentation of seventy-eight papers from fourteen countries. Topics included basic alloy research and development, crystal structures, medical applications, product designs and manufacturing studies. Nitinol alloys contain nearly equal amounts of nickel and titanium. Differences of less than one percent can change the transition temperatures by as much as 150°C. Therefore, the material require very careful formulation and processing. The manufacturer measures the component metals, then melt them together. The cast material is cooled, then rolled and formed into the desired shape. Nitinol's hardness (greater than some steels), and its shape change abilities make processing difficult and more expensive than similar non-memory metals.

When drawn into wires, Nitinol can be easily heated by an electric current and with additional processing, as with Muscle Wire®, the wires can contract and relax for millions of cycles. SMA wires function like electric muscles and could contribute to robotic and prosthetic devices that would be difficult to make using other methods.

Around the world, interest in Shape Memory Alloys continues to grow, and many frontiers await exploration. We hope Space Wings bring you hours of educational fun and leads you to new and interesting discoveries of your own. For more information, see our "Muscle Wires® Project Book". Explore amazing new devices from simple levers to complete motorless miniature walking robots. It includes fifteen fascinating hands-on projects, circuits, devices, history, references, software listing and essential secrets for maximum performance. Contact us for our latest product catalog and technical information!

Solar Space Wings™ circuit designed by Ed Severinghaus.

Contact Us:

Dynalloy, Inc.
14762 Bentley Circle
Tustin, CA
92780

Phone: (714) 436-1206
Fax: (714) 436-0511
E-mail: flexinol@dynalloy.com
Website: MuscleWires.com

For sales, new products and support, go to www.reachinginsight.com.

Comments? Errors? Improvements? Compliments?

Help us make this product better with your feedback. We want to hear from you!